

Mechanical Wastewater Screening



- Reliable screens for any application
- Fine and micro screens for separation of fine suspended material
- Innovative technology from one source

►► Screens for any application

Mechanical treatment is indispensable as the first process step of preliminary treatment for both municipal and industrial wastewater applications.

Initially coarse material has to be removed in order to protect subsequent treatment stages against damage/pollution or to relieve them. The goal is usually to completely separate floating, settling and suspended material, dependent upon the bar spacing or perforation, and remove the material from the flow into a container.

Based on the ROTAMAT® principle of screening – washing – transport – dewatering within one unit a complete ROTAMAT® family was developed and then successfully

launched within the worldwide wastewater treatment market. In recent years the STEP SCREEN® family and now the MAX® family have been added to complement the range. The HUBER screening range therefore comprises of a range of screen systems and enables us to offer the perfect solution for

- any site specific installation conditions
- any flow rate
- any bar spacing



Coarse screen



Fine screen

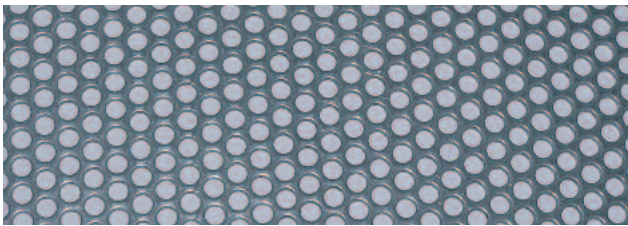

Perforated plate screen

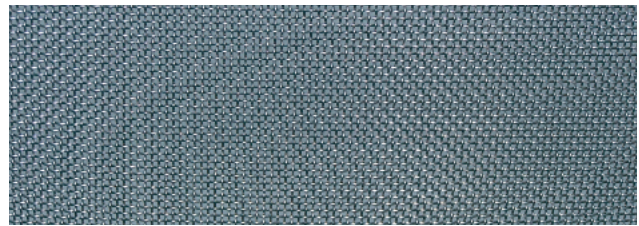

Mesh screen

►► The development of finer screens opens up new fields of application

The development of very fine screens for separation of finer particles opens up new fields of application in wastewater treatment.

For the recently introduced new type of membrane bioreactors within the market an improved performance is required to ensure reliable separation of hairs and fibrous material to allow the membrane process to function effectively.

A further application for these units is river and sea outfalls which frequently only have coarse mechanical screening installed but feel it will increasingly become more common and important to reduce the COD/BOD concentration of the wastewater discharged into the receiving water course. These new fine screens within a single process step can remove undegradable toilet and plastic particles along with organic material contained within the wastewater. The fine screens are equipped with a stainless steel square mesh which provides the defined

separation size that enables an extensive removal of hair and fibres to be achieved. By application of this new technology a high degree of environmental protection can therefore be achieved at a reasonable cost.

The high solids removal rate permits reuse of treated wastewater. If used for irrigation, even the nutrients contained within the treated water can be utilised.

With many regions within the world with no wastewater treatment plants, or insufficient wastewater treatment plants, fine screening can be a first and quick step in the right direction.

➤➤ Mechanical Wastewater Screening – ROTAMAT® Family

➤➤ Design and function

The operation of the ROTAMAT® family screens is based upon a unique system that allows combination of screening, washing, transport, compaction and dewatering in a single unit.

Depending on the screen bar spacing or perforation and screen size (screen basket diameter), the throughput can be individually adjusted to specific site requirements.

The ROTAMAT® screens are installed in the channel with a specific installation angle. Whilst the wastewater flows in through the open front end of the screen basket and through the screen bars or perforations, solids are retained by the screen basket, whereby the separation of floating, settling and suspended solids is dependent upon the screen bar spacing or perforation size. Blinding of the screen surface generates an additional filtering effect so that solids can be retained that are smaller than the bar spacing or perforation. The screen starts to operate when a certain upstream water level is exceeded due to screen surface blinding.

The centrally installed screw conveyor takes up the screenings and transports them upwards within the closed rising pipe.

Whilst the screenings are transported, the screw conveyor dewateres and compacts them without any odour annoyance prior to discharging them into the customer's container or a subsequent conveying unit.

➤➤ Integrated screenings washing system IRGA

The ROTAMAT® principle allows for direct integration of the screenings washing system.

As the soluble matter is separated from the inert material, faeces are virtually completely washed out which leads to a significant weight reduction.

➤➤ The user's benefits

Low headloss – High separation efficiency

Due to the screen basket design and the flat installation a large screening surface is available which results in a low headloss and high separation efficiency.

Corrosion protection

The ROTAMAT® units are completely made of stainless steel and acid treated in a pickling bath.

Small space requirements:

Several functions combined in one system

The ROTAMAT® Screens perform the functions of screenings removal, transport, washing, dewatering and compaction in a single space-saving unit. An additional bagging unit guarantees operation of the entire system without odour nuisance.

Outdoor installation

For outdoor installations, ROTAMAT® Screens can be supplied with a frost protection, combined with an additional insulation, if required.

Retrofitting

The design of the ROTAMAT® Screens allows for later modification so that the systems can be adapted to changing requirements. Both the heating and integrated screenings washing system for example can be retrofitted.

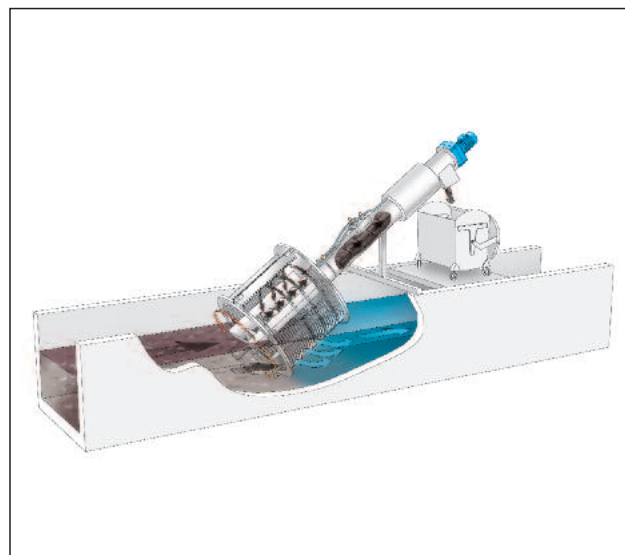

➤➤ Mechanical Wastewater Screening – **ROTAMAT® Family**

➤➤ ROTAMAT® Fine Screen Ro 1

- Screenings removal, transport, washing, dewatering and compaction
- With integrated screenings press
- With integrated screenings washing system (IRGA)
- Enforced cleaning by the action of a rotating rake
- Bar spacing ≥ 6 mm
- Screen sizes (basket diameter): 600 – 3000 mm



ROTAMAT® Fine Screen Ro 1 for installation in a channel or container

➤➤ ROTAMAT® Rotary Drum Fine Screen Ro 2 / RPPS

- Screenings removal, transport, washing, dewatering and compaction
- With integrated screenings press
- With integrated screenings washing system (IRGA)
- Bar spacing:
 - Wedge wire basket (0.5 - 6 mm)
 - Perforated plate basket (0.8 - 6 mm)
- Screen sizes (basket diameter): 600 - 3000 mm



ROTAMAT® Rotary Drum Fine Screen Ro 2 units with closed stainless steel cover

➤➤ ROTAMAT® Micro Strainer Ro 9

- Screenings removal, transport, washing, dewatering and compaction
- With integrated screenings press
- With integrated screenings washing system (IRGA)
- XL-version with an extended screen basket for a higher throughput, suited for narrow and deep channels
- Economy version Ro 9Ec
- Screen basket opening: 0.5 - 6 mm bar spacing
1 - 6 mm perforation
- Screen sizes (basket diameter): 300 - 700

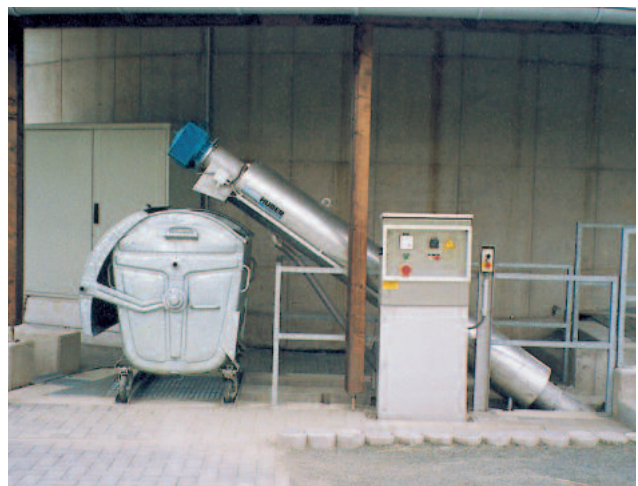

ROTAMAT® Micro Strainer Ro 9 – the cost-efficient solution for small flow rates

➤➤ Mechanical Wastewater Screening – ROTAMAT® Family

➤➤ Screening of large volumes of wastewater SGAM

- Treatment of dry weather and average flow by the main screen
- Activation of the bypass screen at a predetermined high flow level
- Reduced settling processes due to optimised flow conditions
- Specifically suited for sea and river outfall applications



Combination of different screening systems for optimised treatment of large volumes of wastewater

➤➤ ROTAMAT® Sludge Acceptance Plant Ro 3

- Mechanical treatment of septic sludge with ROTAMAT® Fine Screen Ro 1, Rotary Drum Fine Screen Ro 2 / RPPS, or ROTAMAT® Micro Strainer Ro 9
- With integrated screenings press
- With integrated screenings washing system (IRGA)
- Optional as a complete plant Ro 3.3 with integrated grit trap



ROTAMAT® Sludge Acceptance Plant Ro 3 – a worldwide well-proven solution

➤➤ ROTAMAT® Screw Conveyor Ro 8 / Ro 8t

- Screw conveyors with customised design and manufacture
- Available as a closed pipe conveyor (Ro 8) or screw trough conveyor (Ro 8t)



ROTAMAT® Screw Conveyor Ro 8 / Ro 8t, applicable for any type of screenings transport

➤➤ Mechanical Wastewater Screening – **STEP SCREEN® Family**

➤➤ Design and function

The STEP SCREEN® System is widely accepted and successful due to its function and easy-to-follow operation principle as well as the simple cleaning method without any aids (self-cleaning effect according to the counter-current principle). It is furthermore easy to maintain and able to handle extremely big screenings volumes while it offers also a high operational reliability.

The motor linkage drive has been developed from the well-proven and patented link system. To the benefit of our customers we intentionally avoided difficult-to-maintain chain drives. With the new linkage type we are able to master the occurring bending moments on the lamellae, especially with high water levels.

The solids contained blind the screen surface producing a mat of screenings that has the effect of a filter the pores of which retain also smaller solids than the actual slot width would allow.

➤➤ The user's benefits

Lifting of screenings at bottom level

- due to a special bottom step design

Separation efficiency:

- High separation efficiency due to the narrow slot width and the produced screenings carpet

Cleaning:

- Self-cleaning effect due to movable lamellae

Operational stability:

- Reduced susceptibility to grit, gravel and stones due to the bottom step washing system

Protection against corrosion:

- Manufactured from stainless steel and acid treated in a pickling bath

Experience:

- Unrivalled for more than 20 years

Pivoting arrangement:

- Removal of the subsequent wash press or conveying unit is not required.

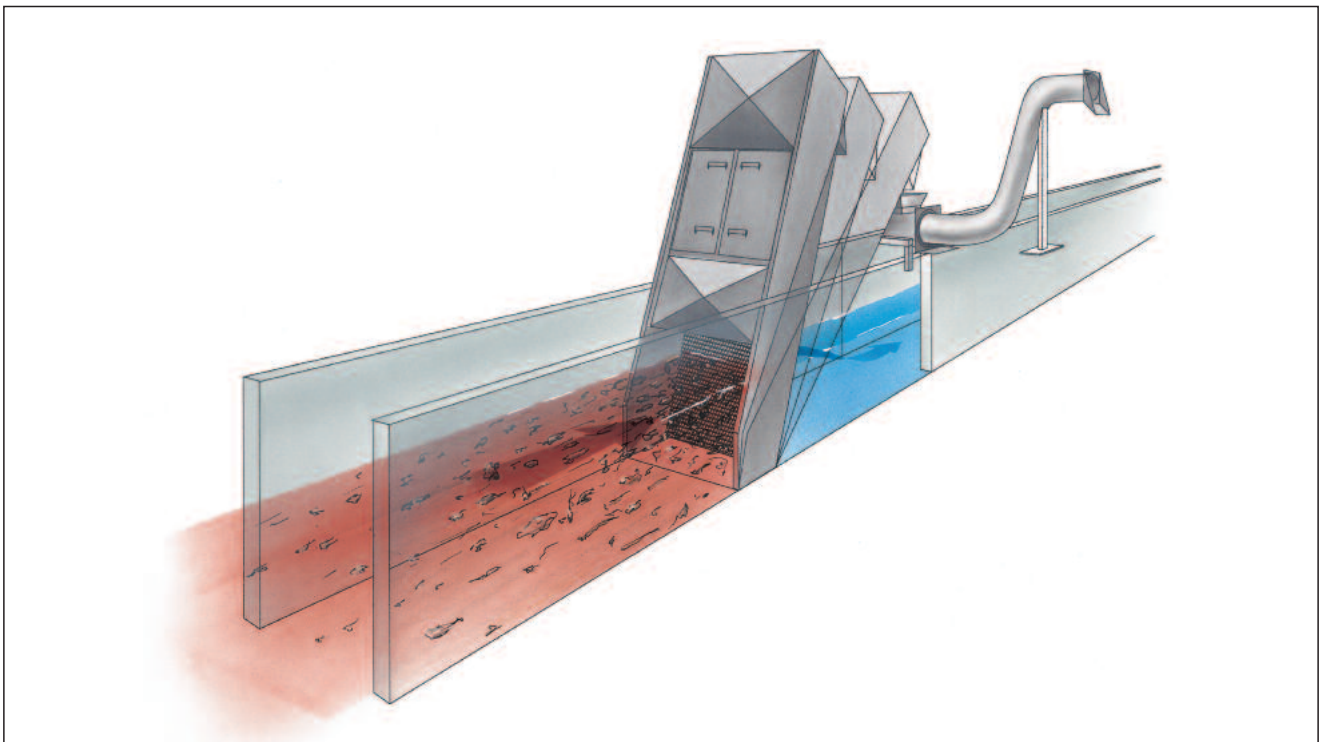

➤ Installation examples of the HUBER STEP SCREEN® Flexible SSF



STEP SCREEN® Flexible SSF: length 3500, width 1826, slot width 6 mm, installation angle 50 °, high capacity as the flow passes the screen surface only once.



STEP SCREEN® Flexible SSF with HUBER Wash Press for optimal separation and dewatering results. Acid treated in a pickling bath for corrosion protection.



STEP SCREEN® Flexible SSF combined with HUBER Wash Press type SL for intensive screenings washing. Totally enclosed, odour-free design.



STEP SCREEN® Flexible SSF: very high operational stability and reliable operation without impairment by grit, gravel and stones due to the special bottom step design for lifting of screenings at bottom level.



STEP SCREEN® Flexible SSF application in Russia: pivotable in the channel without having to remove the downstream HUBER Wash Press and HUBER Screw Conveyor



STEP SCREEN® Flexible SSF: high separation efficiency due to the narrow slot width and the produced screenings carpet, self-cleaning effect due to a moveable lamella unit

➤ Installation examples of the HUBER STEP SCREEN® SSV



3 STEP SCREEN® Vertical SSV units: length 4300, width 1176, slot width 3 mm. Optimally adjustable to suit specific constructional conditions (big discharge height, deep channel) due to the steep installation angle of 70° to 80°



4 STEP SCREEN® SSV units: length 5300, width 1376, slot width 6 mm, installation angle 75°. Maximum operational stability without impairment by grit, gravel and stones due to the special bottom step design.

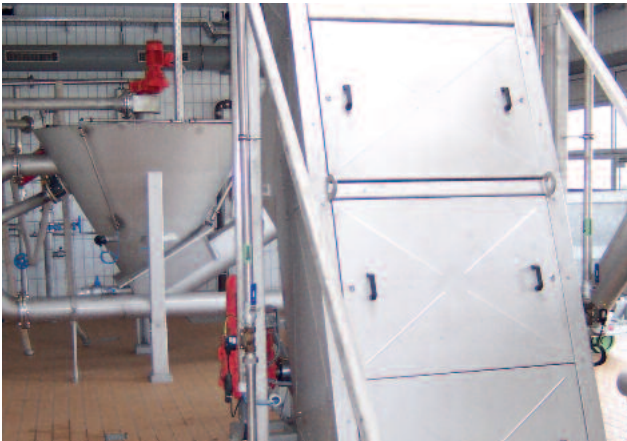

STEP SCREEN® Vertical SSV in channel, pivotable without having to remove the downstream HUBER Screenings Wash Press



STEP SCREEN® Vertical SSV: 4300 mm long, 3 mm slot width, acid treated in a pickling bath for optimal corrosion protection



STEP SCREEN® Vertical SSV: very high separation capacity due to the fine slot widths and the produced screenings carpet



2 STEP SCREEN® Vertical SSV, length 4300 mm, width 1676, 6 mm slot width, combined with HUBER Wash Press type SL for intensive screenings washing. Totally enclosed, odour-free design.

➤➤ Mechanical Wastewater Screening – Max[®] Family

➤➤ RakeMax[®] – Design and function

The cleaning elements, attached to the chain system, can easily be adjusted to different requirements, the screenings discharge capacity is then extremely variable. This is especially favourable for high solids loads. The cleaning elements, consisting of the rake and comb plate, are screwed and thus independently replaceable.

The installation height of the RakeMax[®] above ground level is very small and only dependent, even in case of deep channels, on the installation height of screenings transport or washing units.

Both ends of the cleaning elements are connected to drive chains. Each chain is driven by a sprocket on a common shaft and a flange mounted gear motor. Furthermore, defined meshing of the cleaning rakes with the bar rack ensures a high operating reliability. If the screen operation is blocked, a mechanical overload protection interrupts the operation.

- Very high screenings discharge capacity
- Low headloss
- Low installation height above ground level even in deep channels
- Control-independent safety system
- Bar spacing ≥ 1 mm



Reliable, sturdy travelling RakeMax[®] screen

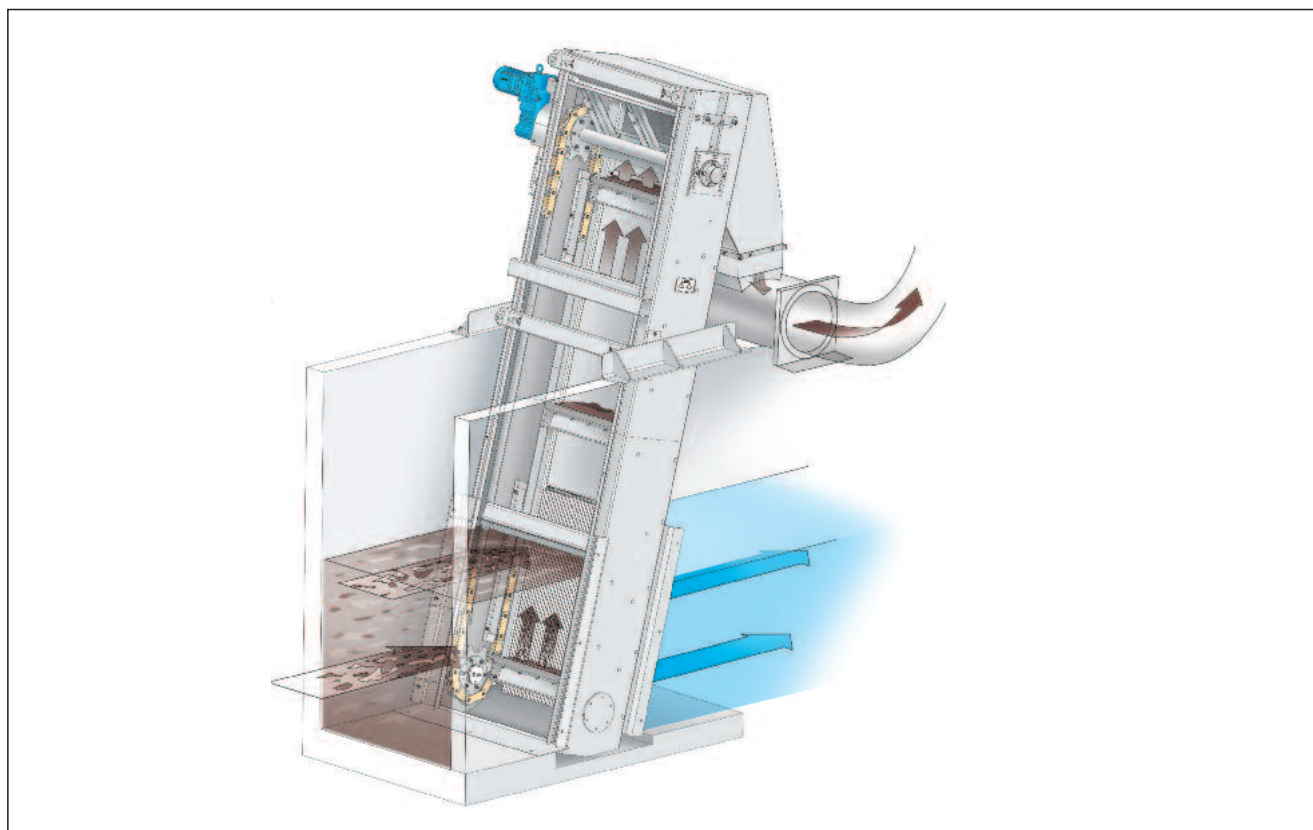

➤ Mechanical Wastewater Screening – Max® Family

➤ RakeMax®-hf (high flow) – Design and function

The HUBER RakeMax®-hf Multi-Rake Bar Screen is the 'high flow' version and further development of the successful HUBER RakeMax® Multi-Rake Bar Screen that is well-proven in hundreds of installation. The RakeMax-hf® screen consists of a flat and therefore hydraulically advantageous bottom section and a steep conveying section.

Material removal from the screen starts virtually right at the bar rack mounted flat to the channel bottom so that any accumulation of disturbing material is eliminated. The optimal approaching flow conditions and large effective bar rack surface ensure a high hydraulic throughput capacity.

The cleaning elements, attached to the chain system, can easily be adjusted to different requirements, the screenings discharge capacity is then extremely variable. This is especially favourable for high solids loads. Depending on the size of bar spacing, the bar rack design is either a flow-optimising bar or non-blocking wedge wire profile.

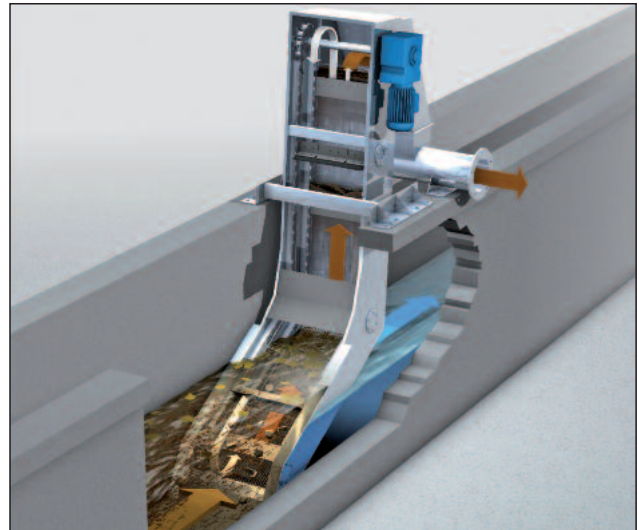

The RakeMax®-hf (high flow) combines low headloss with high screenings discharge capacity

➤ CurveMax® – Design and function

The HUBER Curved Bar Screen CurveMax® is perfectly suited to both municipal and industrial wastewater, and process water screening. Material removal from the bar rack starts at a tangent to the channel bottom so that any accumulation of disturbing material is eliminated. The optimal approaching flow conditions and large effective bar rack surface ensure a high hydraulic throughput capacity under any operating conditions.

The rake mounted on the rake arm cleans the curved bar rack. Depending on the bar spacing, the bar rack design is either a bar or non-blocking wedge wire profile.

At the end of the bar rack cleaning cycle the rake is cleaned by a pivoted comb discharging the removed screenings into a downstream unit.

As the cleaning velocity is variable, the screenings discharge capacity is then adjustable. This is particularly beneficiary in case of increased screenings loads, e. g. due to sudden peak loads caused by emptying of upstream stormwater tanks.



Compact HUBER Curved Bar Screen CurveMax® for reliable separation of solids from wastewater

➤➤ Mechanical Wastewater Screening – Max[®] Family

➤➤ EscaMax[®] – Design and function

The screening elements of the EscaMax[®] are perforated plates. Each end of the perforated plates is connected with a drive chain, each chain is driven by a sprocket on a common shaft and a flange mounted gear motor.

At their upper turning point the perforated plates are continuously cleaned by a fast counterrotating brush which increases the cleaning energy and thus significantly improves the cleaning efficiency. Cleansing is supported by an integrated spray bar.

The sturdy EscaMax[®] screen is able to reliably cope with even high amounts of gravel and grit. The two-dimensional screening elements prevent especially long fibres from passing through the screen and achieve thus the maximum separation efficiency.

- Optimal efficiency due to a counterrotating brush
- Excellent separation efficiency due to its two-dimensional perforated screening elements
- Very compact system with minimum space requirements

- Easy-to-retrofit into existing channels
- Optimally suited for deep channels with high water levels
- Perforation ≥ 3 mm



HUBER Belt Screen EscaMax[®] – a versatile inlet screen

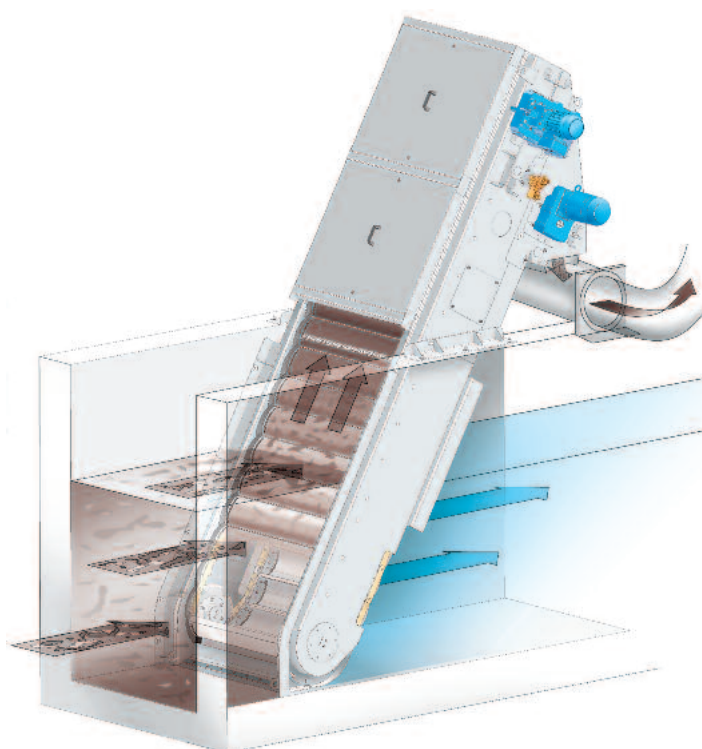

➤➤ Mechanical Wastewater Screening – **Max[®] Family**

➤➤ ClimbMax[®] – Design and function

The screening element of the ClimbMax[®] consists of a bar rack that is cleaned when blinded by a rake that is mounted to a movable cleaner carriage.

The lateral frames with the pin gear construction are normally embedded in concrete in the lateral channel walls.

As an option, the lateral frame with the pin rack construction can be installed without any modification of the channel wall where required.

The ClimbMax[®] is typically used as a front cleaned screen but may under certain conditions (water level, bar spacing) also be operated as a back cleaned screen. Back cleaned installations offer the possibility of submerging the bar rack for emergency operation.

This option is particularly favourable where no emergency by-pass is available.

- Sturdy construction, operationally reliable, minimum maintenance
- Easy-to-retrofit into existing channels
- Available as front or back cleaned screen
- No submerged moving parts
- Bar spacing:
Front cleaned screen ≥ 6 mm
Back cleaned screen ≥ 15 mm



ClimbMax[®] Screen – a well-proven solution for large flows

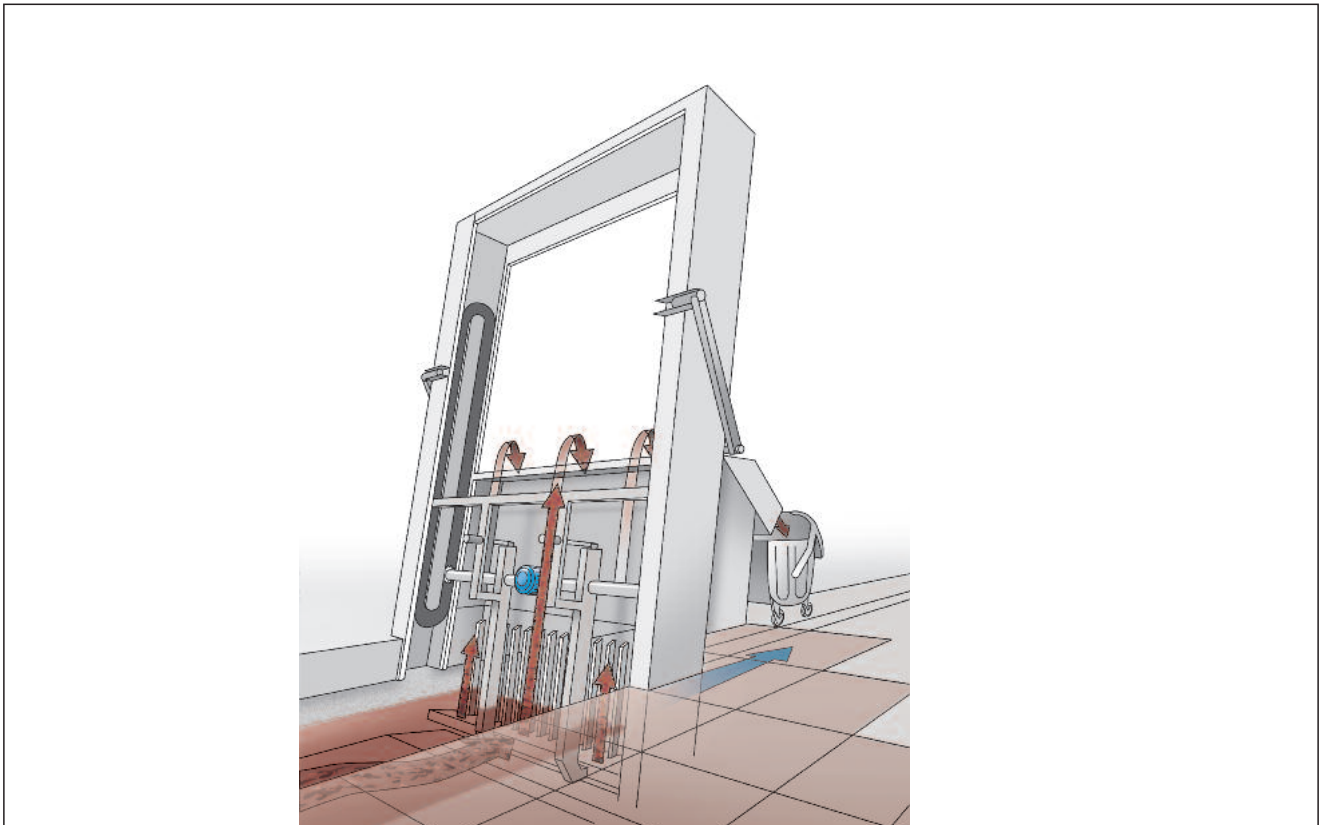

➤➤ Mechanical Wastewater Screening – Fine Screening

➤➤ Square mesh screen

Removal of hair and fibres

The removal of hairs, fibres and fine suspended material is a prerequisite for trouble and maintenance free operation of subsequent treatment steps. Separation of fibrous material is particularly important for hollow fibre membrane plants as they require very fine prior screening in order to prevent blocking by hairs and fibres which impair the membrane permeability and hydraulic capacity of the membrane plant. The conventional screening systems available with 3-10 mm bar spacing or perforation are unable to meet these requirements. Finer screens are a reliable solution to mechanically eliminate such material.

To achieve removal of high oxygen-consuming loads, screening elements with very fine apertures, preferably square mesh, are used. Their two-dimensional design combined with the defined separation size of the square mesh enables an extensive removal of solids to be achieved. In addition the very fine square mesh has a very large free surface area and is therefore able to cope with high hydraulic capacities. With the two-dimensional design, very fine apertures and the defined separation size provided by the square mesh, it will prevent in particular fibres and hairs being washed through the mesh before the screen basket surface is cleaned.

The volume of screenings produced proves the high efficiency of square meshes. Compared to a wedge wire with a comparable bar spacing, a square mesh is able to separate up to three times more solids when handling municipal wastewater after a preceding coarse screen. In addition, square meshes have a very large free surface and are therefore able to cope with high hydraulic capacities despite their fine mesh.

River or sea outfall applications

Fine screens are particularly suited for application in river or sea outfalls which frequently have only coarse mechanical screening installed, in order to minimise the oxygen-consuming loads of the wastewater discharged into the receiving watercourse and prevent thus overloading of the watercourse due to the increasing oxygen demand. The BOD₅ reduction of 20 % and filterable solids reduction of 50 % demanded by the North Sea bordering states can be achieved with the use of very fine mesh screens.

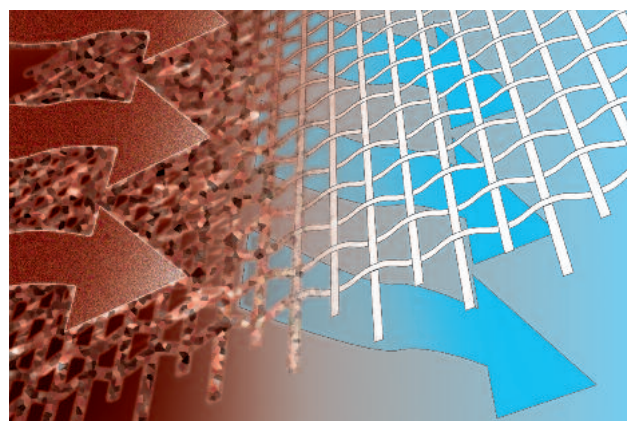

Maximum separation efficiency due to the square mesh that provides a defined separation size

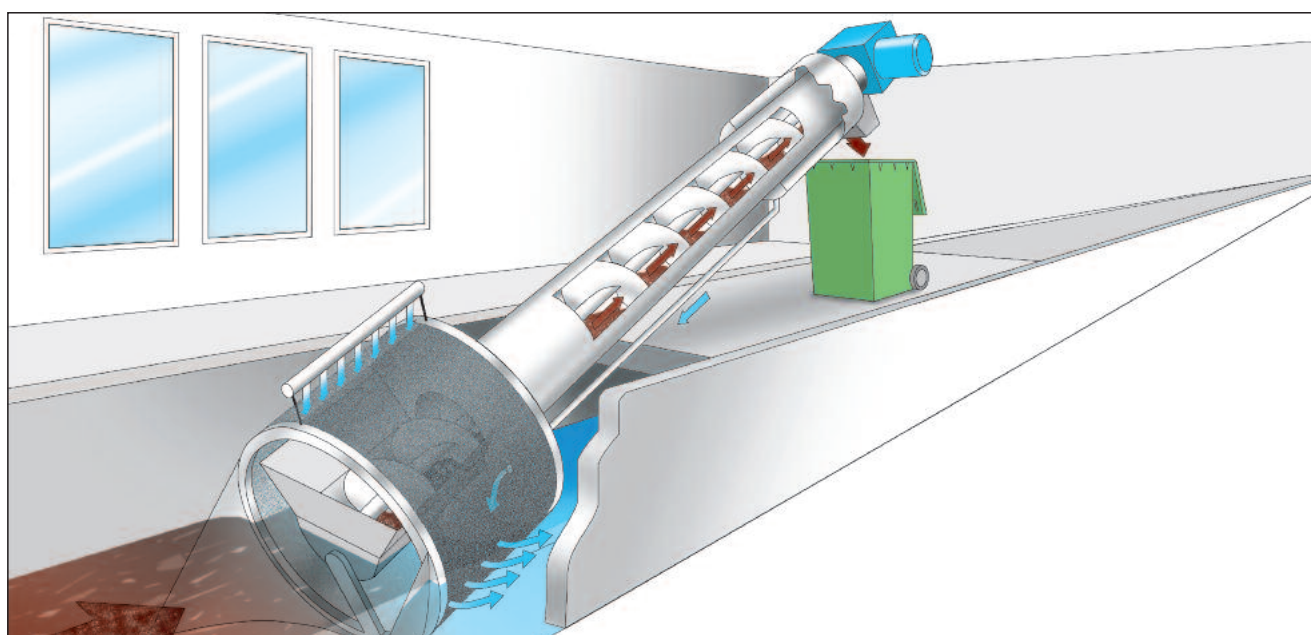

Schematic diagram of the ROTAMAT® Membrane Screen RoMem

➤➤ Mechanical Wastewater Screening – **Finer Screens**

➤➤ ROTAMAT® Membrane Screen RoMem liquid Screen RoMem liquid

- Removal of hair and fibres to protect downstream membrane filtration plants
- COD and BOD removal prior to river or sea outfall applications
- Ideal for installation in existing channels
- Suction and transport of sludgy screenings for further treatment (e.g. combined treatment with sewage sludge)
- Mesh size from 0.2 mm to 1.0 mm
- Perforation from 0.8 to 3 mm



ROTAMAT® Membrane Screen liquid with screenings discharge by pump

➤➤ ROTAMAT® Rotary Drum Screen RoMesh®

- For a fine, specified separation size
- For removal of hairs, fibres and fine suspended material
- Reduction of COD/BOD in river and sea outfall applications
- Insensitive to the high inlet concentrations of industrial wastewater
- Throughput of up to 1000 m³/h, mesh size 0.1 - 1.0 mm, perforation up to 6 mm



ROTAMAT® Rotary Drum Screen RoMesh® with 0.5 mesh size for wash water recovery

➤➤ ROTAMAT® Membrane Screen RoMem

- Removal of hair and fibres to protect downstream membrane filtration plants
- Increased operational stability of MBR plants
- Ideal for installation in existing channels
- Screening, compaction, dewatering and transport of screenings in one unit
- 1.0 mm mesh size



ROTAMAT® RoMem for increased operating reliability of MBR plants

➤➤ Mechanical Wastewater Screening – **Micro Screen**

Municipal applications

Due to high hydraulic loads, insufficient tank depth and poor settling behaviour of the activated sludge, secondary clarifiers are frequently unable to reliably ensure the solids retention required. Under storm conditions, the amount of filterable solids can be up to three to four times the volume experienced under dry weather conditions. The increased COD, BOD and phosphorus load of the effluent will finally lead to higher wastewater fees and the loading of the receiving water-course with oxygen-consuming substances.

Frequently, further reduction of the filterable solids in the secondary clarifier effluent is required, in particular where the wastewater is discharged into weak receiving water-courses. The required low solids content of < 5 mg/l can only be reliably achieved by means of a subsequent filtration unit, such as the HUBER Micro Screen.

Micro screening retains filterable solids and prevents eutrophication and thus the growth of algae and other plants in waters.

Industrial applications

Micro screening is increasingly gaining in importance due to the growing environmental sensitivity in terms of the avoidance of waste. Preparation of wastewater from production processes, which contains suspended solids, is increasingly demanded to achieve recycling and reuse of the valuable resource water. Valuable materials should not be disposed of but micro screened so that they are available for reuse, such as for plasterboard or textile production.

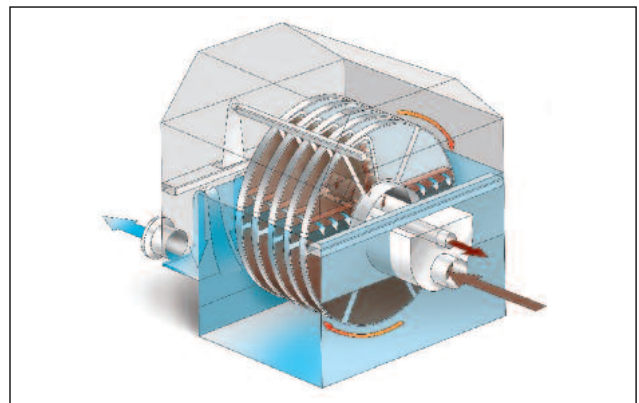

RoDisc® Rotary Mesh Screen

➤➤ **RoDisc® Rotary Mesh Screen**

- Significant reduction of filterable solids and COD/BOD/P concentrations in the WWTP effluent
- Preliminary filtration in drinking water recovery from surface waters and in UV disinfection applications
- Gravity system with a large separation surface
- Can reduce wastewater fees
- Throughput of up to 2000 m³/h, mesh size as small as 10 µm



RoDisc® Rotary Mesh Screen for retention of activated sludge flocs

➤ Installation examples



Tank-mounted ROTAMAT® Rotary Drum Fine Screen Ro 2 / RPPS



ROTAMAT® Membrane Screen RoMem prior to a hollow fibre membrane plant

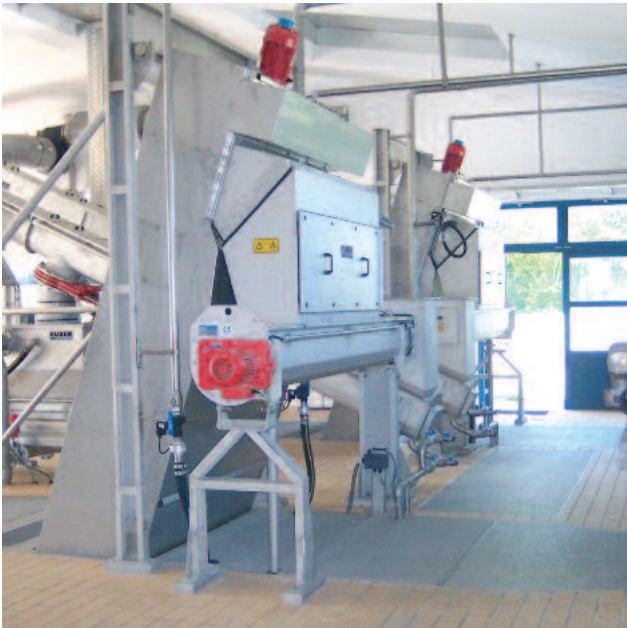

Enclosed STEP SCREEN® SSV for odour-free screenings discharge



ROTAMAT® Sludge Acceptance Plant Ro 3.3, compact plant with grit trap and grit classifier