



ALSYS thickening modules

Easy, convenient sludge thickening



Concept

The ALSYS thickening module range from Alfa Laval comprises a number of standardized modules ready for immediate installation on delivery. Since the capacity of these modules is considerable, they are the ideal choice for municipal, industrial and potable water treatment plants. The ALSYS thickening modules were designed to handle a variety of commonly encountered sludge types that can be flocculated.

The modular design considerably facilitates installation because the only connections to be made after delivery are to sludge, water, polymer and electricity. The ALSYS thickening modules are assembled on a framework that is fully equipped with stairs and walking bridges, as well as all necessary internal wiring and piping. Prior to delivery, the ALSYS thickening modules are thoroughly tested by Alfa Laval. A central control panel ensures trouble-free operation with built-in safety.

The ALDRUM drum thickener, which rests on a stainless steel structure, is part of the ALSYS thickening module. The following options can be added to suit different thickening needs and to provide flexible solutions:

- ALDRUM flocculation reactor
- ALDRUM sludge hopper
- ALDRUM outlet adapter
- sludge feed pump
- discharge pump
- polymer make-up unit
- control panel or junction box
- flow meter

All ALSYS thickening modules are available in either AISI 304 stainless steel or AISI 316 stainless steel.

Benefits

The ALSYS thickening modules provide the following benefits:

- a series of factory assembled modules, with a hydraulic range 2 - 180 m³/h / approx. 5 - 800 GPM.
- user-friendly modules for convenient operation and service
- all components selected, tested and approved by Alfa Laval to ensure compliance with specifications
- time-saving, cost-effective engineering, installation and commissioning
- automatic, unattended operation that saves manpower and provides smoother operation
- "plug and play" concept for easy installation and commissioning

System overview

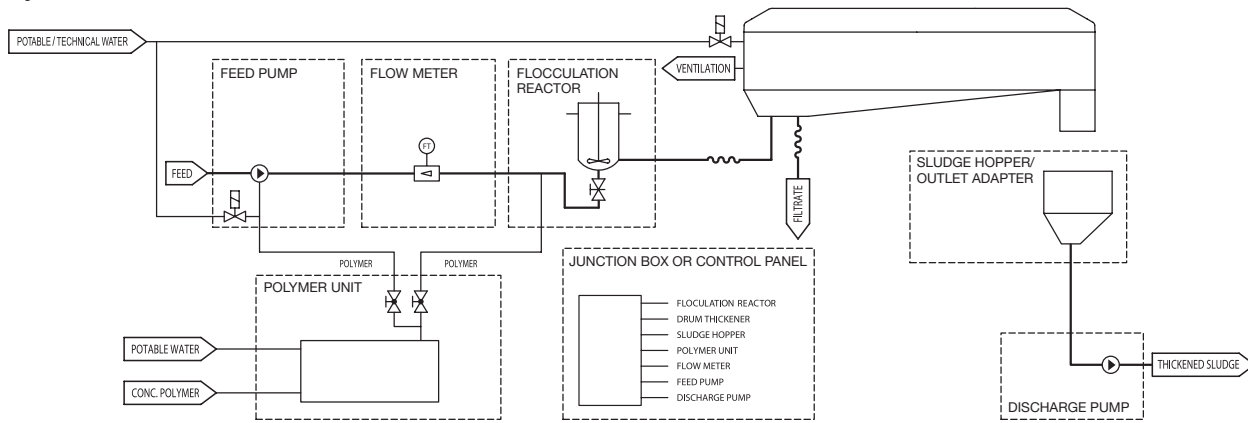

Operating principles

The sludge feed pump draws the feed sludge from a storage tank, and a flow meter determines the sludge flow. Sludge is first mixed with polymer from the polymer make-up unit before reaching the ALDRUM flocculation reactor. This flocculated sludge then flows to the ALDRUM drum thickener by force of gravity.

The ALDRUM drum thickener was designed to handle the flocculated sludge extremely gently, which means it has an excellent recovery rate for all types of sludge. Adjusting the feed rate, polymer dose, angle and speed of the drum regulates the concentration of the sludge. The thickened sludge is then discharged into the ALDRUM sludge hopper, and filtrate is returned to the head of the plant. A discharge pump empties the thickened sludge from the ALDRUM sludge hopper.

The ALSYS thickening modules were designed for unmanned operation, and a complete module is operated by a control panel provided with a PLC. The entire process is easy to monitor using various sample points. This gives a better overview of the unit's operation and assures the best performance.

Configuration

The ALSYS thickening module always consists of the ALDRUM drum thickener and the stainless steel frame. To fully customize to individual needs, the optional equipment includes the ALDRUM flocculation reactor, ALDRUM sludge hopper, ALDRUM outlet adapter, sludge feed pump, discharge pump, polymer equipment, control panel/junction box, flow meter and access stairs.

Dimensions	Mini	Midi	Maxi	Mega	Mega Duo
L * (mm/inch)	3615 / 142	4070 / 160	7310 / 288	8320 / 328	8980 / 354
H * (mm/inch)	1885 / 74	2730 / 107	3520 / 139	3745 / 147	3745 / 147
W * (mm/inch)	1040 / 41	1790 / 70	2215 / 87	2450 / 96	4450 / 175
Weight (kg/lb)*	1300 / 2866	1800 / 3968	3400 / 7496	4900 / 10802	8700 / 19180

* Maximum weights and dimensions

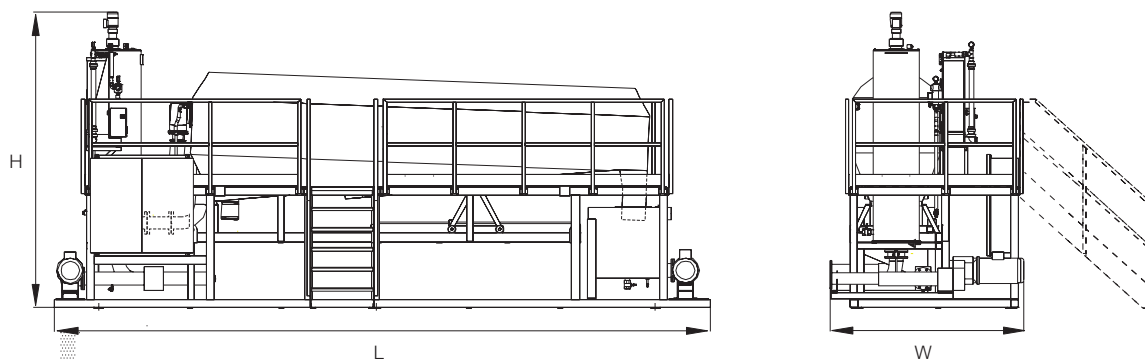

PEE00025EN 0401

How to contact Alfa Laval

Contact details for all countries are continually updated on our website. Please visit www.alfalaval.com to access the information direct.