

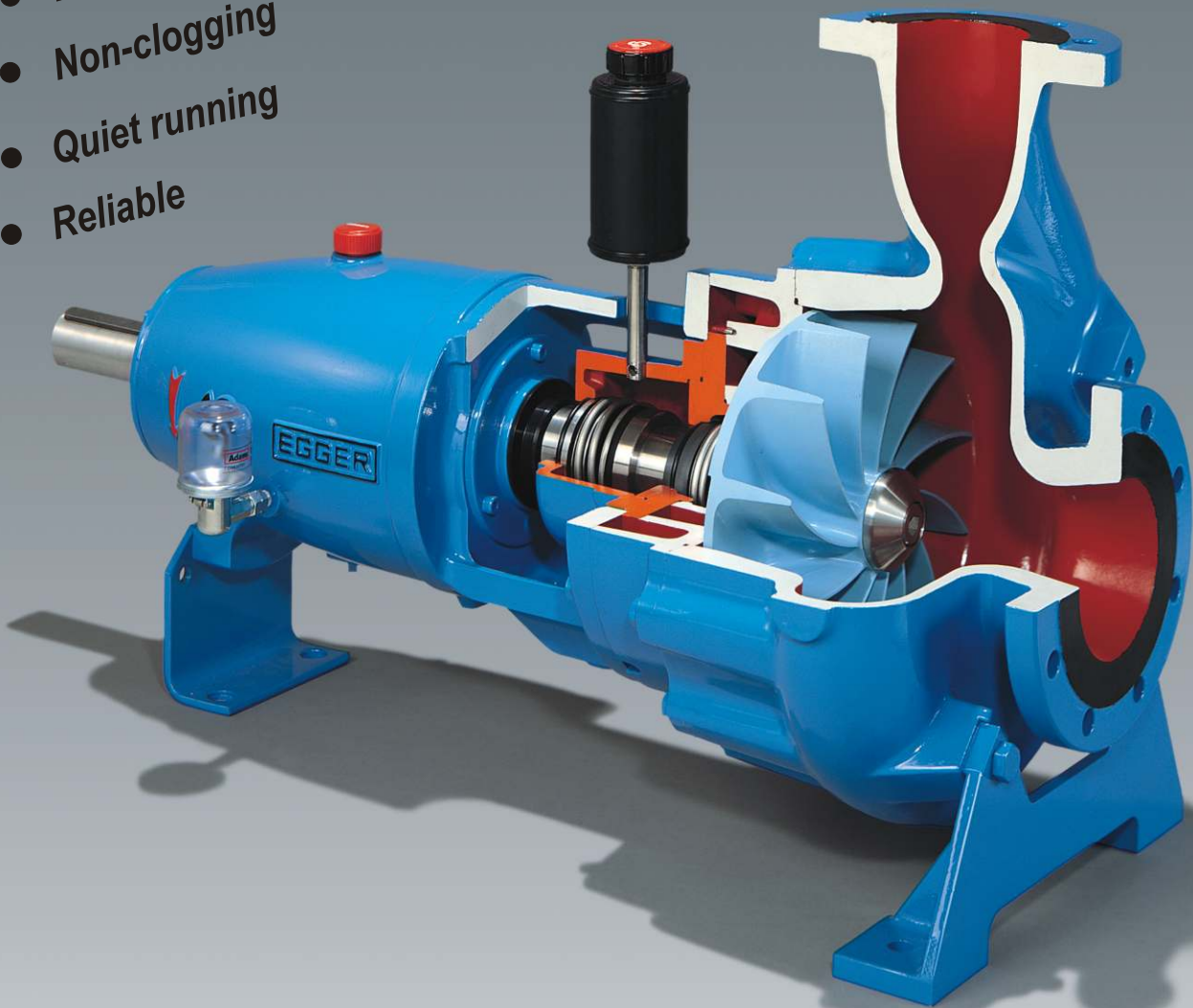

Vortex Pump Programme Series T

Recessed Impeller Pumps

- High efficiency
- Economic
- Free passage
- Non-clogging
- Quiet running
- Reliable



The non-clogging TURO pumps



is the worldwide protected trade name for the EGGER vortex pumps.

The latest TURO design enhances the principle of a hydro-dynamic liquid coupling to transport the pumped medium.

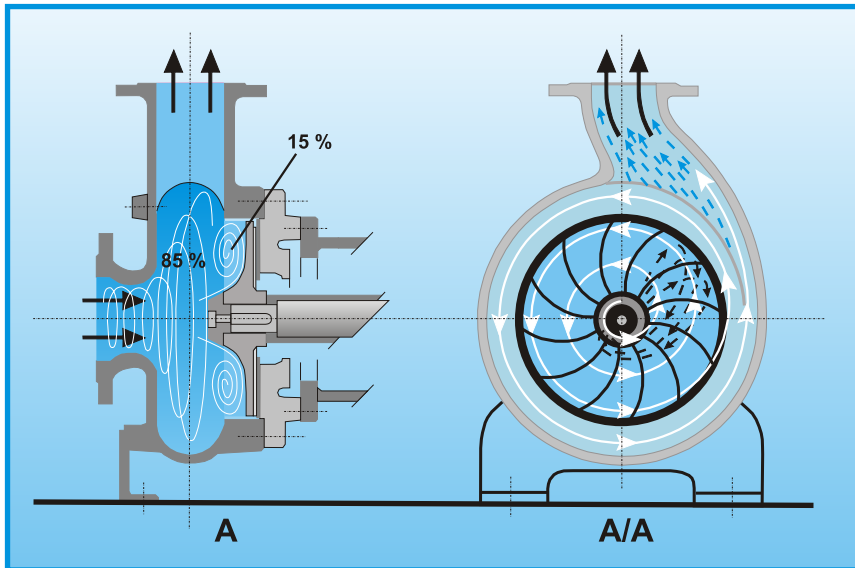

The TURO Vortex pumps have the benefit of EGGER's 45 years experience in solids handling applications. The experience is reflected in today's designs.

The TURO pump is a single stage end suction, radially split casing pump, with centre-line discharge, incorporating the back pull-out feature.

Separately mounted pump feet allow the discharge to be positioned 90° either side of the pump centre-line. It also permits the use of one standard pump casing for all different pump designs shown on page 5.

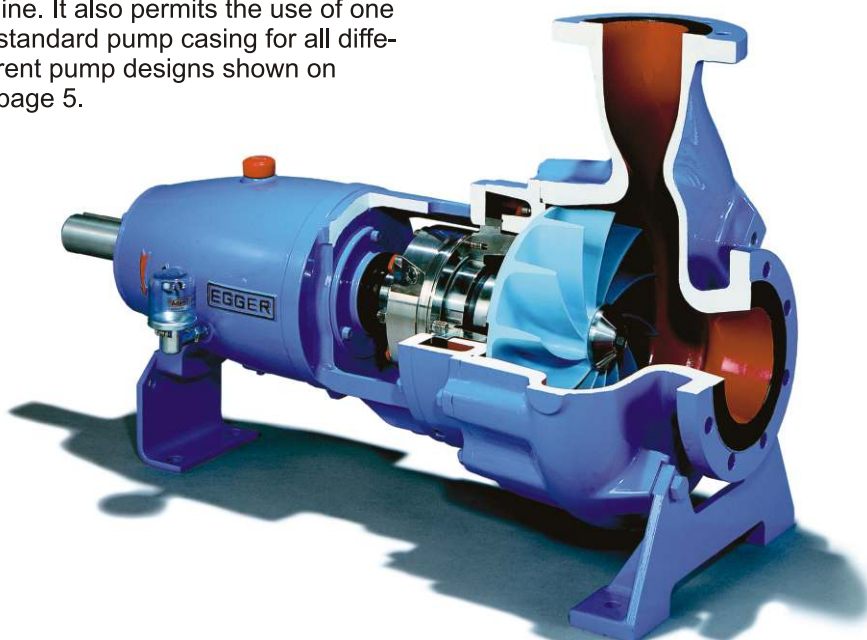
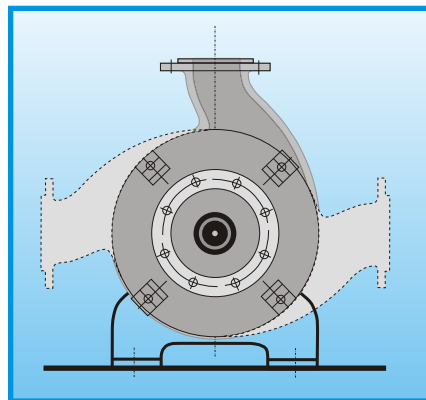

TURO advantages

- **Non-clogging**

The recessed TURO impeller permits an unobstructed passage through the pump casing, and this allows solids up to virtually the full diameter of the discharge port size to pass through without the danger of clogging.

- **Improved hydraulic efficiencies**

The TURO pump design incorporates an axial spiral in a concentric casing, this ensures that solids entrained in the flow are quickly discharged from the pump thereby reducing internal recirculation, which is detrimental to hydraulic efficiencies and pump wear life.

- **Low attrition of medium**

Due to natural flow of the fluid through the pump casing and the fact that the flow is virtually isolated from the impeller, fragile solids such as crystals, carbon and live cockles etc. can be passed through the pump with very little damage. Ideally suited for low shear applications.

- **Simple design**

The hydraulic centering of the impeller in the casing and its simple open design results in very little radial loadings on shaft and bearings. Even under extreme conditions when wear occurs on the impeller, it is concentric and does not affect the mechanical balance of the TURO pump.

- **Low running costs**

Due to the improved hydraulic efficiencies of the TURO pumps, they absorb less power than other designs of vortex pumps. The gentle pumping action also contributes to improved wear life of component parts.

- **Reliability**

The robust and simple design together with correctly chosen materials guarantee a long service life. Time has proven that TURO pumps require very few spare parts compared with other makes of pumps.

- **Standardized programme**

Because of a maximum interchangeability of parts in different pump sizes and designs, spares can be reduced to the absolute minimum.

TURO Pump applications

Automobile industry

Dye liquor, bonder-emulsion, grinding dust and corundum slurries, soluble oil and swarf, paint sludge, solvent/water based primers, coagulation sludge transfer, phosphate sludge.

Sugar industry

Beet and beet chip-mixtures, beet tails, leaves and grass with water, milk of lime at 95°C, lime sludge from the setting tanks, kieselgur, unscreened sugar juice.

Building industry

Gas-concrete slurry, sand, gravel, stone and marble dust in water, creosote solutions.

Textile industry

Natural- and artificial fibres, dyes with slub, fibrous waste water, fleece scouring.

Dredging industry

Sand, gravel, mountain slip, lake and harbour cleaning.

Fibre industry

Fibre-cement slurry, rockwool, leatherfibres, glasfibres, textile-fibres, nitro-cellulose.

Powerstations

Ash, dust-screen sludge.

Chemical industry

Crystal suspensions, filters slurries, latex, polystyrene beads in water, caustic soda solutions 50%, hot brine, washing powder slurries, zinc slurry, paint suspensions, bicarbonate slurry, catalytic sludge, etc.

Steel industry

Scale in water, ash-shoot-slurries, coke and coal water mixtures, borax suspensions.

Mining

Leached gold ore slurries, stone slurries, betonite, coal washing " water, mine drainage pumps, manganese dioxyde slurry.

Cellulose industry

Semi-chemical pulp, sulphite-sulphate pulp, black-liquor, wood chips, pulp with knots, digester emptying pumps, splinters from woodgrinder.

Shipbuilding

Sewage, bilgewater, fish-offal.

Petrochemical industry

Slops, catalytic sludge, carbolated oil, drilling sludge, raw tar with coke.

Paper industry

Uncleaned wastepaper, straw pulp, rag pulp, defibrator pulp, Kaolin 80%, bagasse, bambus, rejects, pulper rejects.

Food industry

Potato waste, peas, beans, carrots, turnips, pig food, fruit suspensions, chicken/turkey waste with feathers, live cockles, bone meal slurry.

Waste water treatment

Raw unscreened sewage, raw sludge, digested sludge, grit channel pumps, abattoir waste water, all municipal and industrial effluents, granulated activated carbon.



Programme Lay-out

The TURO Vortex modula pump programme consists of:
 23 pumps of 8 different sizes
 DN 32 to DN 200. For each bearing housing size there is only one impeller per pump size.

TV = Pump sizes which can be delivered in wear resistant material. Casing, casing cover and impeller in HG 15-3.

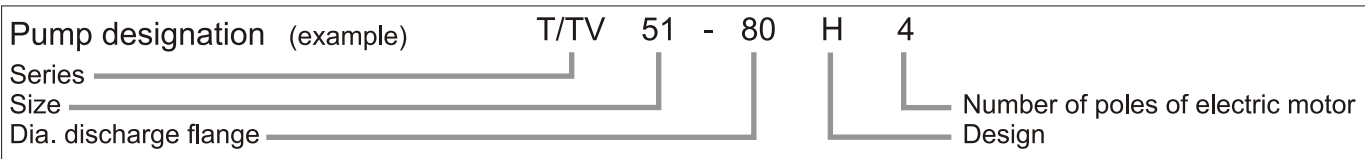
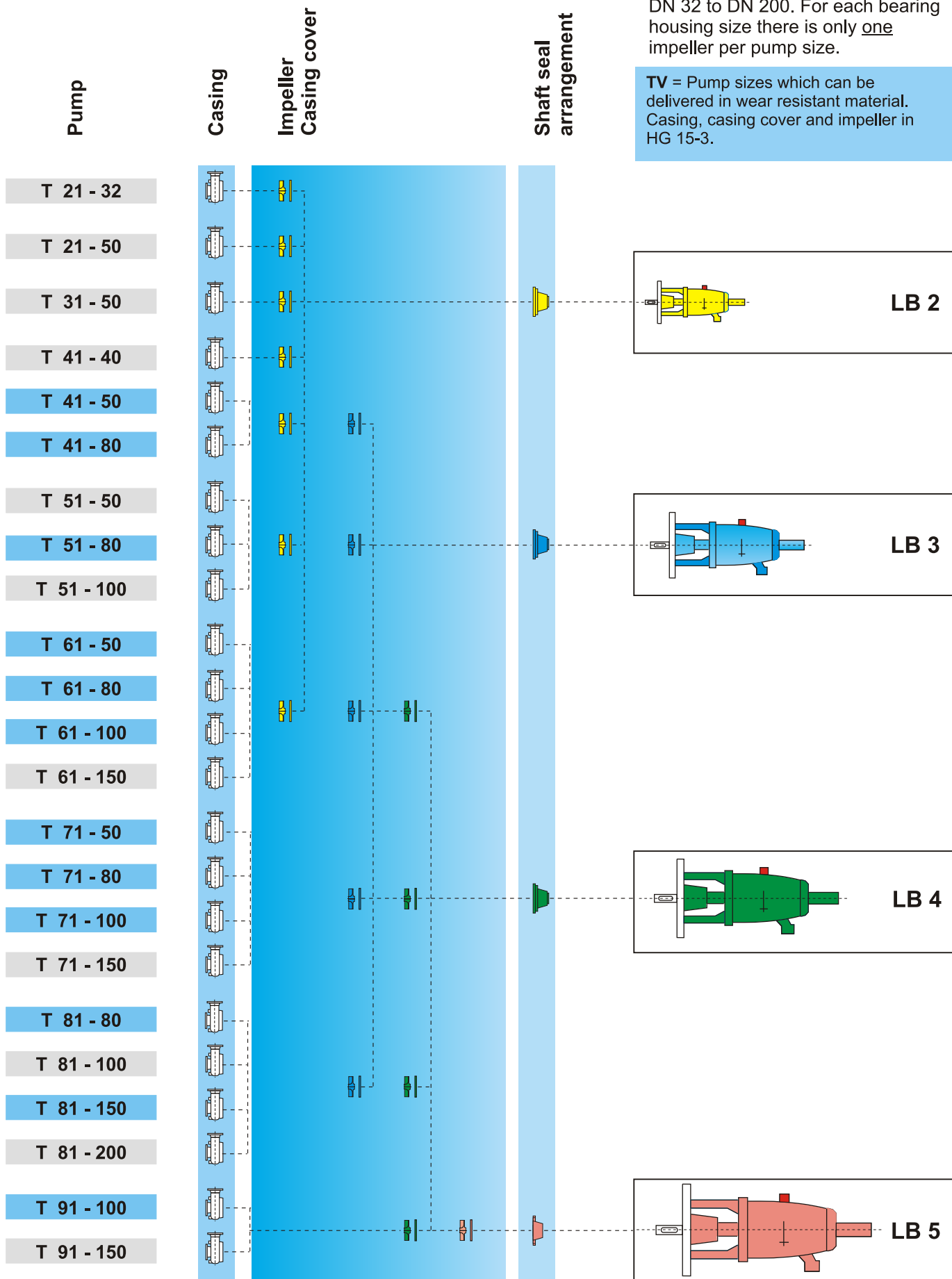

Summary of Designs

Description of designs:

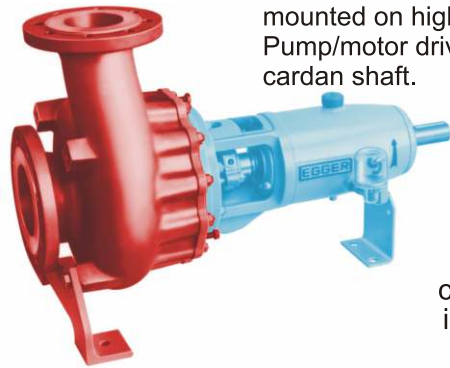
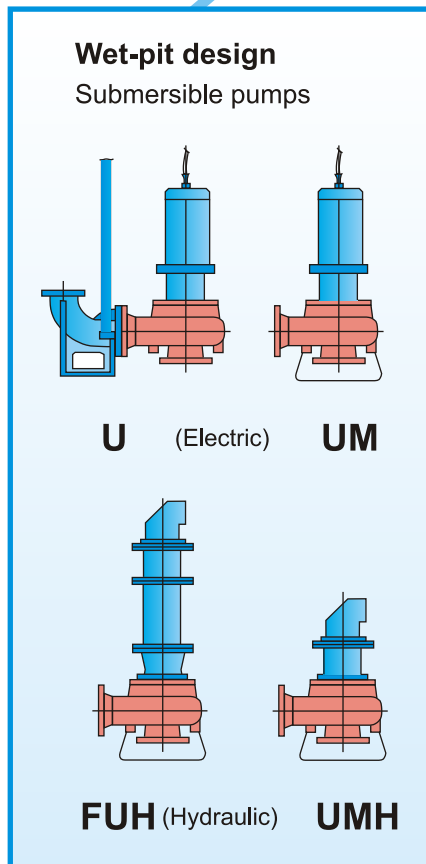
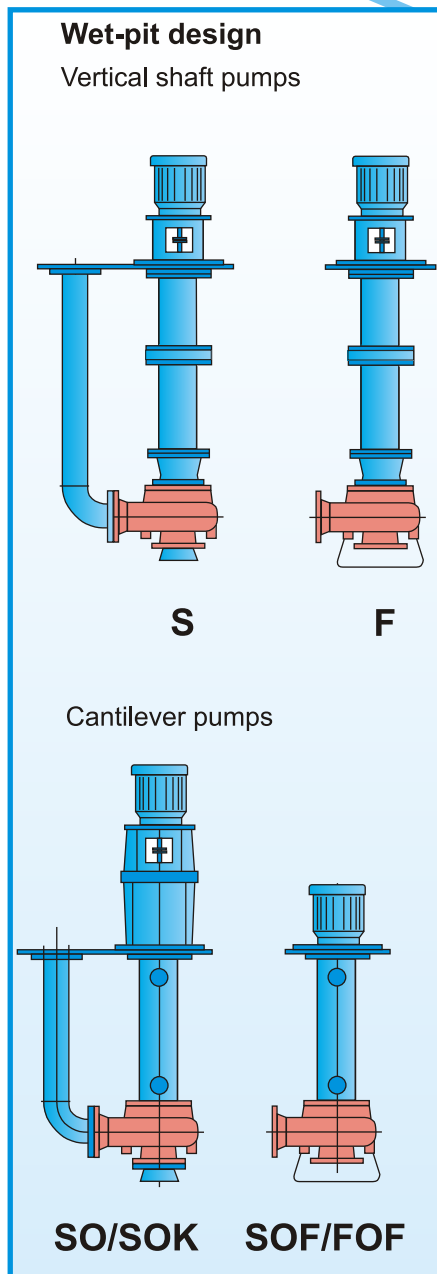
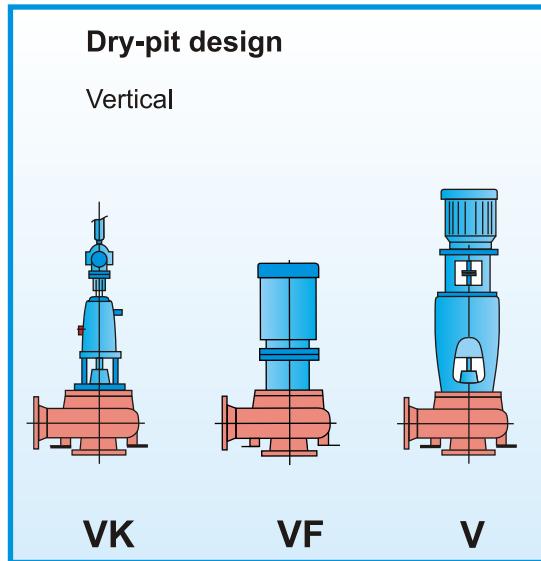
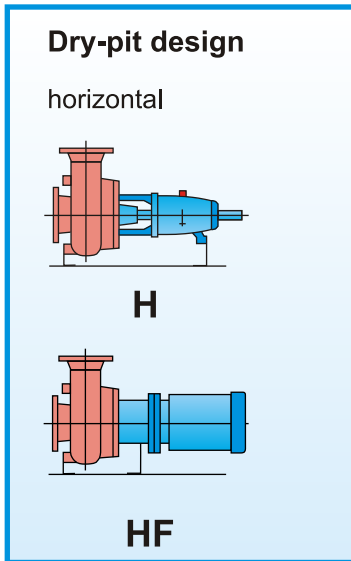

H = horizontal pump with bearing housing. Pump either with standard packing or mechanical seals (acc. DIN 24960).

HF = horizontal close-coupled pump, impeller directly fitted to motor stubshaft. IEC standard flange-/foot motor. Can only be fitted with mechanical seals (acc. DIN 24960).

VF = vertical arrangement, pump details identical HF.

V = vertical dry-pit pump with bearing housing. Flange motor fitted on motor support with flexible coupling. Pump either with standard packing or mechanical seals (acc. DIN 24960).

VK = pump details identical H, however motor for safety reasons mounted on higher level. Pump/motor drive by means of cardan shaft.

Standard casing identical for all designs.

Suction and discharge flanges can comply to most international flange standards.

S = vertical wet-pit design (pump). Motor dry mounted, shaft, bearings and intermediate couplings enclosed in intermediate pipe.

F = verticale wet-pit design (pump). Motor dry mounted, shaft, bearings and intermediate couplings enclosed in intermediate pipe. Without pit-cover, with pedestal.

SO/SOK = vertical cantilever type pump design, no bearings, bushes, or shaft seal in pumped liquid.

SOF/FOF = cantilever pump details identical SO but close-coupled pump.

U = submersible stationary pump with duckfoot-bend and pipe coupling.

UM = submersible mobile pump.

UMH = as UM but with hydraulic motor instead of electric motor.

FUH = pump details similar F, driver submersible motor.

H-Series bearing housings

Bearing housing design

The horizontal TURO pump programme comprises of four different bearing housing sizes. Depending on the bearing load, the motor-side bearings can be supplied in the following assemblies A, B or C.

Bearing assemblies

Standard design A

On either side a single deep groove ball bearing.

Heavy duty design B

Motor-side two angular contact ball bearings.

Extra heavy duty design C

Motor-side three angular contact ball bearings.

Assembly C

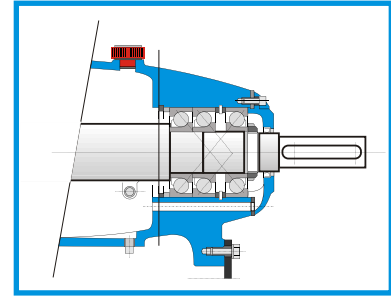

Assembly B

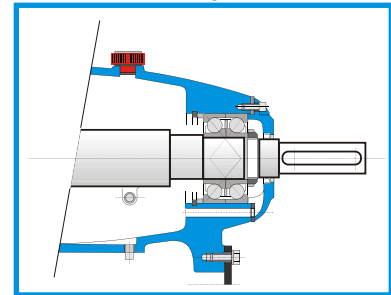

Assembly A

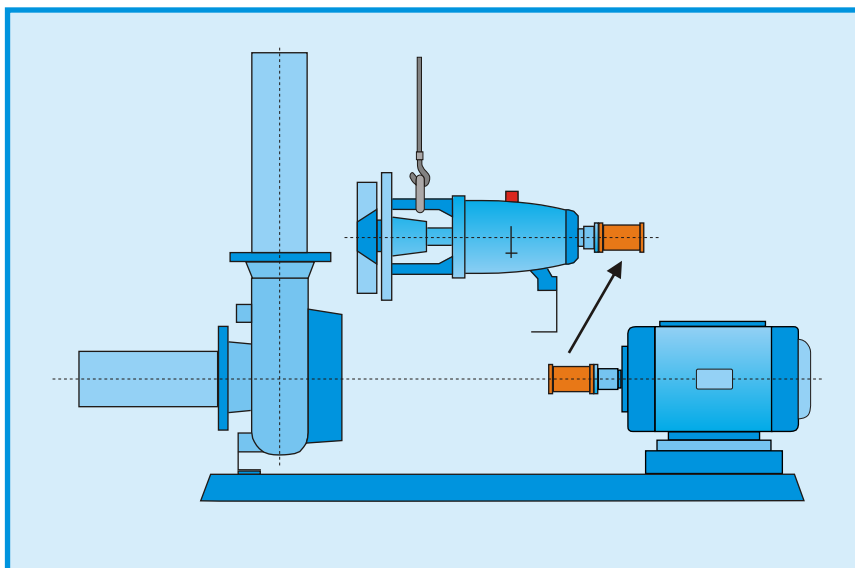
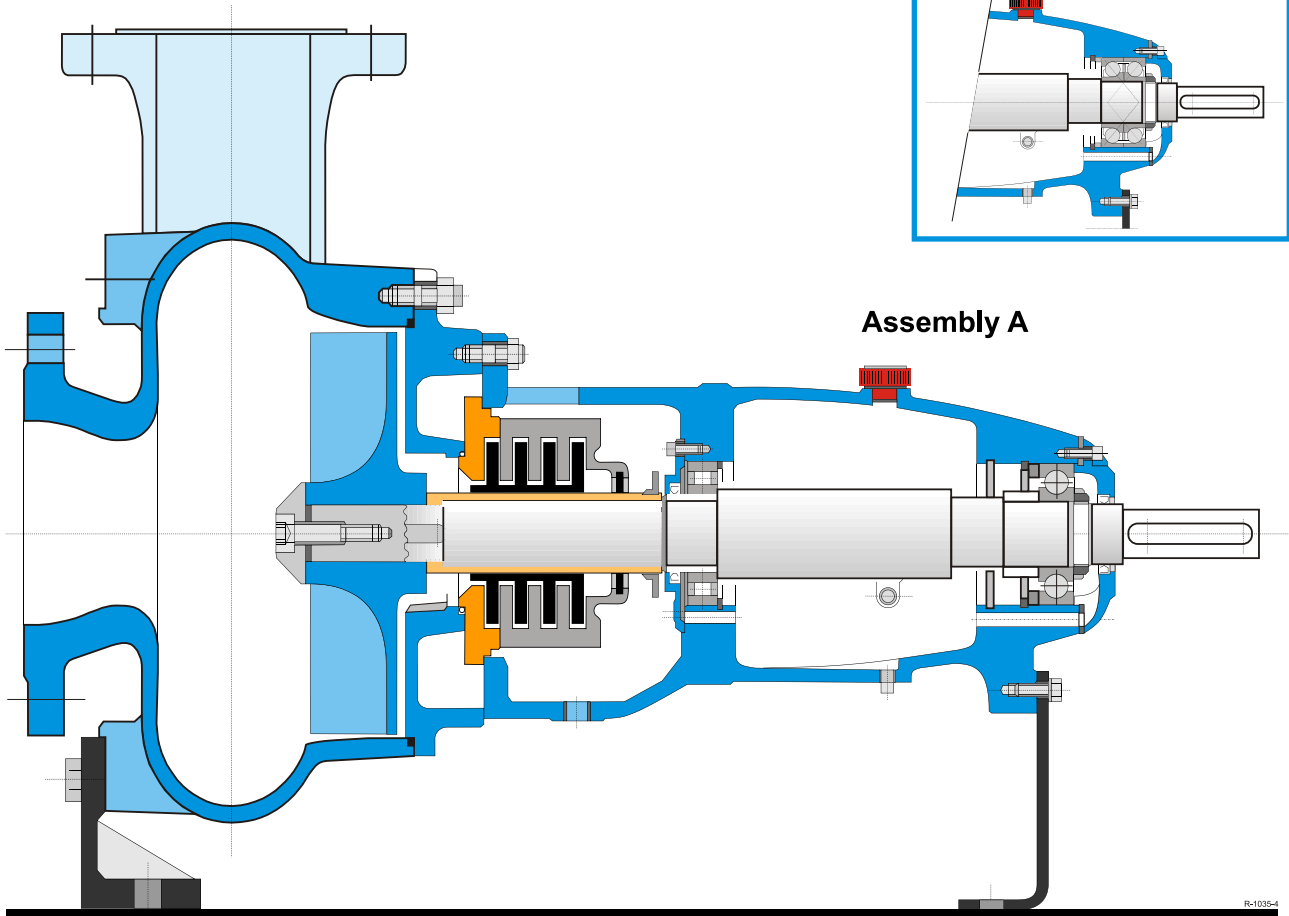

All horizontal bearing housings have as standard, oil lubrication for the ball bearings. Greased bearings can be supplied on request.

Vertical dry-mounted bearing housings for design V/VK are grease lubricated.

Simple construction and maintenance.

“Back pullout” feature.

Using a spacer coupling, the complete rotating assembly can be removed easily without disconnecting suction/discharge piping or the motor.

Shaft sealing system EGGER-VARIOSEAL®

The shaft seal is designed in such a way that different seal arrangements can be fitted without modification to the pump casing cover.

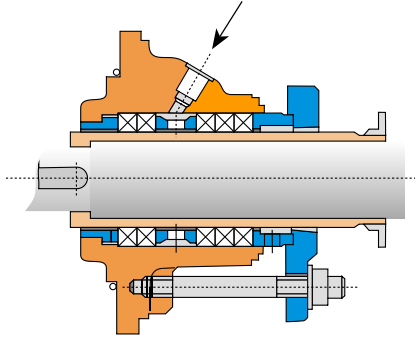

All standard elements to DIN - dimensions:
 - Stuffing boxes DIN 3780
 - Mechanical seals DIN 24960

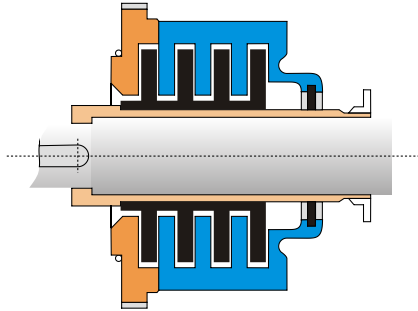

All usual stuffing box arrangements possible acc. DIN 3780

The **hydrodynamic EURO-DYN®** cartridge seal is fully integrated into the EGGER modular design programme.

- Wide choice of shaft sealing arrangements
- the same shaft sleeve is used for all shaft seal arrangements
- minimum number of spare elements
- easy maintenance
- the shaft is always sealed from the pumping liquid. Therefore the shaft is always in standard high tensile steel independent of the pump construction materials

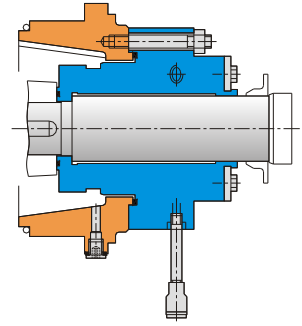
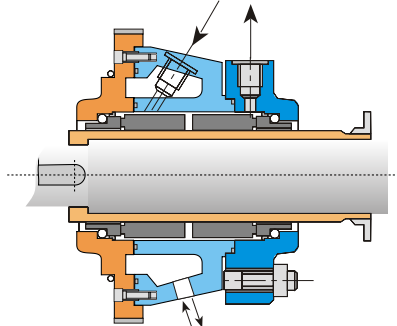
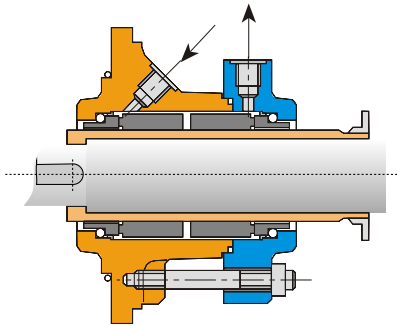

Double mechanical seal acc. DIN 24960 (L_{1K}), back-to-back with external sealing liquid.

Double mechanical seal acc. DIN 24960 (L_{1K}), back-to-back with external sealing liquid. Seal casing with cooling or heating jacket.

Special arrangements are possible (e.g. mech. seals with stationary springs). Flushing connections are provided for.

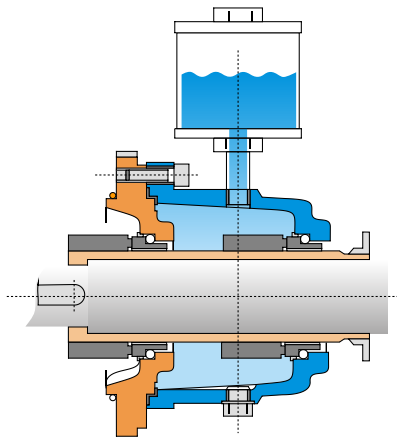
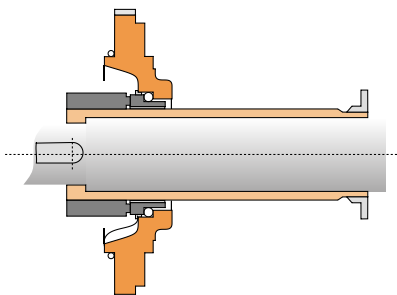

Single mechanical seal acc. DIN 24960 (L_{1K}), (without sealing liquid)

Double mechanical seal acc. DIN 24960 (L_{1K}), in tandem (with pressureless internal sealing liquid)

Bearing housing (LB)	Shaft sleeve Ø (mm)	Stuffing box insert Inside (mm)	Packing ring Ø (mm)
2	35	51	8
3	48	68	10
4	65	90	12.5
5	90	122	16
6	130	170	20

Material - Standard Assembly

Item	GG	1.4408	HG 15-3
Casing	GG25	1.4408	HG 15-3
Impeller	GG20	1.4408	HG 15-3
Casing cover	GG25	1.4408	HG 15-3
Stuffing box insert	GG20	1.4408	GG20
Shaft sleeve	GGK-FP	1.4408	GGK-FP+ Eut. 12 496
Shaft	CK45	CK45	CK45

Material Qualities Used:

GG

Cast-iron according to DIN 1691
(BS 1452: 1961/ASTMA 48-74)
hardness GG25 = 180 - 240 HB
hardness GG20 = 170-210 HB

1.4408

stainless steel according to DIN mat. No. 1.4408
BS 3100: 1976 316 C / Aisi 316
Analysis: 18-20 % Cr; 10-12 % Ni; 2,0-3,0 % Mo;
max. 0.07 % C; 1.5 % Mn; 1.5 % Si; 0.03 % S; 0.45 % P.
hardness 130-200 HB

GGK - FP

Special fine grain chilled iron
mat. structure ferritic - pearlitic
Härte: 160-220 HB
hard coating with Eut. 12496, hardness 55 -62 HRC.

HG 15.3

Abrasion resisting alloyed cast-iron according to
DIN mat. No. 0.9635, nomination G-X300 CrMo 15.3
analysis: 2.7 % C; 0.6 % Si; 0.5 % Mn; 15.0 % Cr; 0.7 % Ni; 2.8 % Mo.
Hardness 55-65 HRC (600-830 HV)

Service temperatures for standard materials upto 130°C.
Higher temperatures and other material on request

Coupling guards are available with comply to latest international safety standard.



TURO-Pump
with V-belt drive.

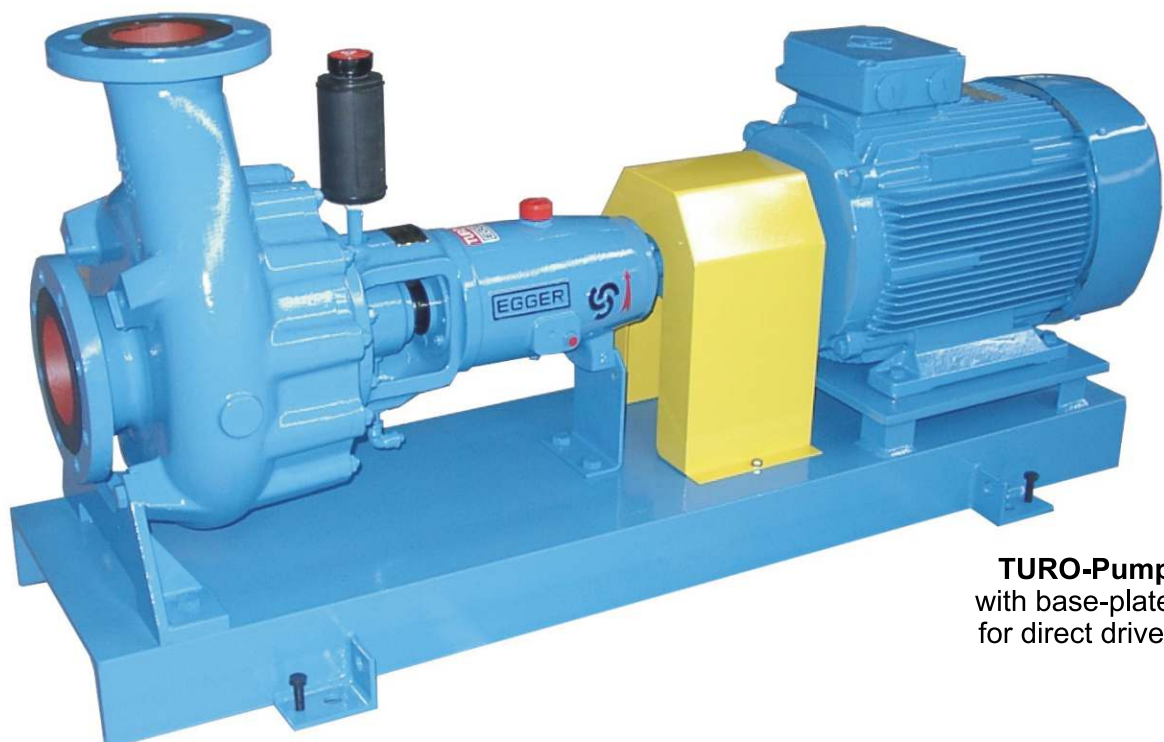

TURO-Pump
with base-plate
for direct drive.

Series T Performance Curves

50 Hz

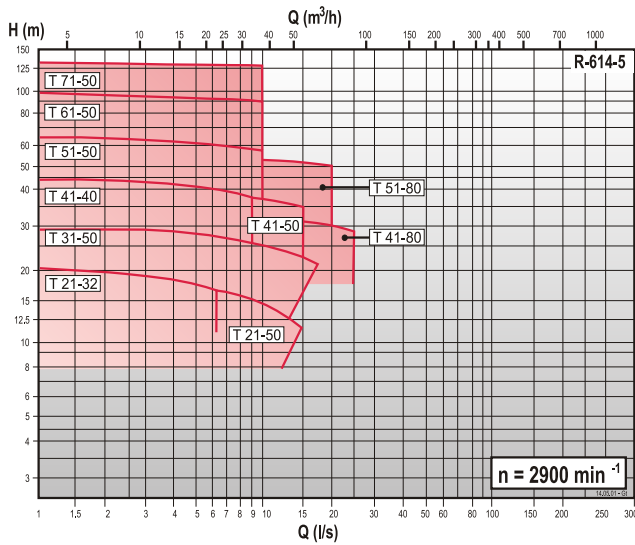

60 Hz

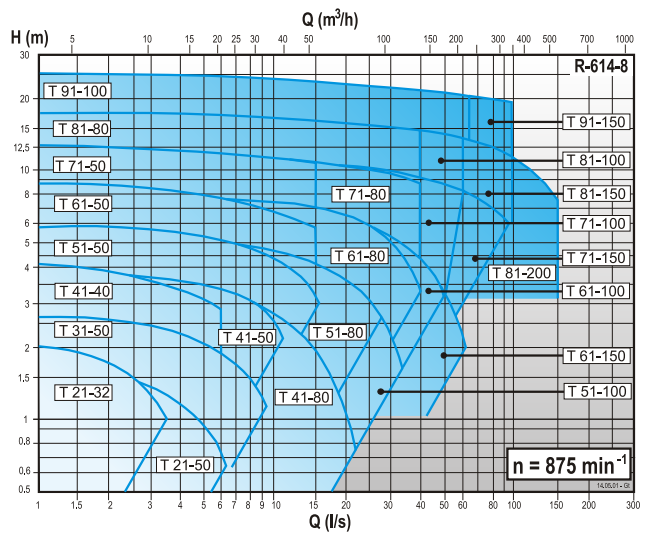
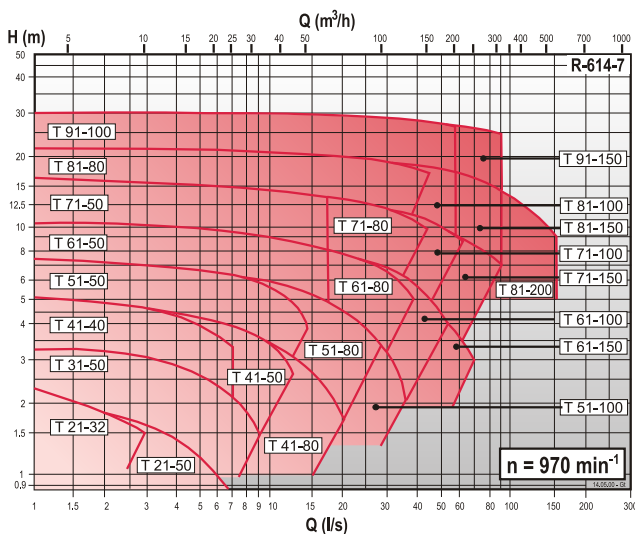
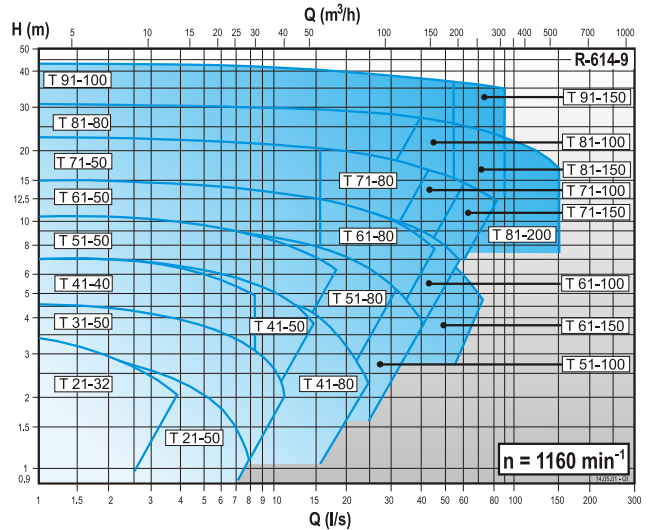
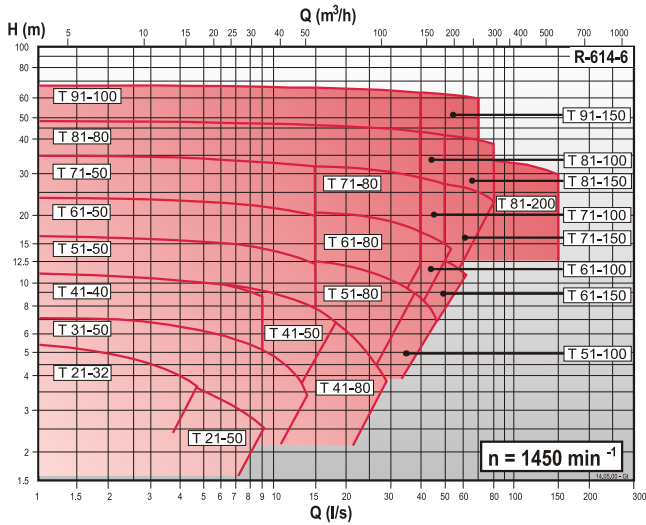
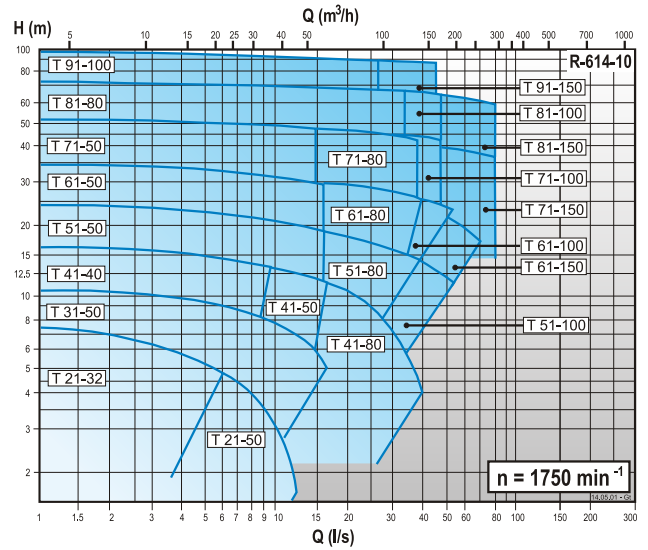

1 m = 0.1 bar = 3.28 ft - 1 m³ = 220 Imp.Gal. = 264 U.S. Gal.