

Here is your conveying solution:
Product group N.



N – Standard pumps

The two ranges of pumps within the product group N form the basis of all seepex progressive cavity pumps. They are available with various rotor/stator geometries (conventional, 6L, and Tricam) and can be applied in virtually all industrial sectors – for conveying thin to viscous media with or without solids.

Joint connection
consisting of just 5 components.
Power transmission through wear resistant, hardened and replaceable joint parts: easily repaired.

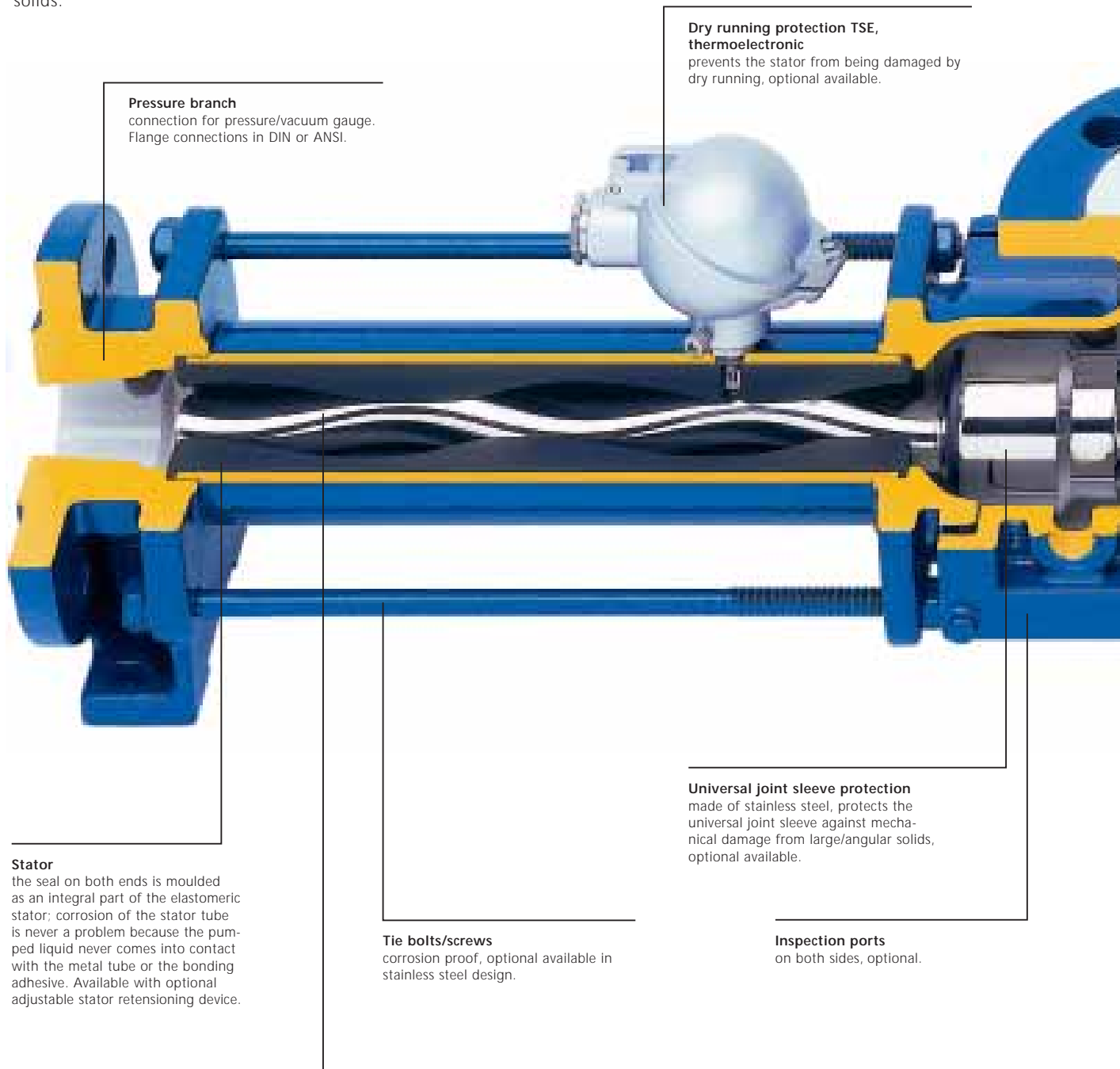

Pressure branch
connection for pressure/vacuum gauge.
Flange connections in DIN or ANSI.

Dry running protection TSE, thermoelectronic
prevents the stator from being damaged by dry running, optional available.

Stator
the seal on both ends is moulded as an integral part of the elastomeric stator; corrosion of the stator tube is never a problem because the pumped liquid never comes into contact with the metal tube or the bonding adhesive. Available with optional adjustable stator retensioning device.

Universal joint sleeve protection
made of stainless steel, protects the universal joint sleeve against mechanical damage from large/angular solids, optional available.

Tie bolts/screws
corrosion proof, optional available in stainless steel design.

Inspection ports
on both sides, optional.

Rotor
wear resistant and corrosion-proof materials, with additional surface treatment.

Coupling rod
for power transmission. Improved design, special designs optional available.

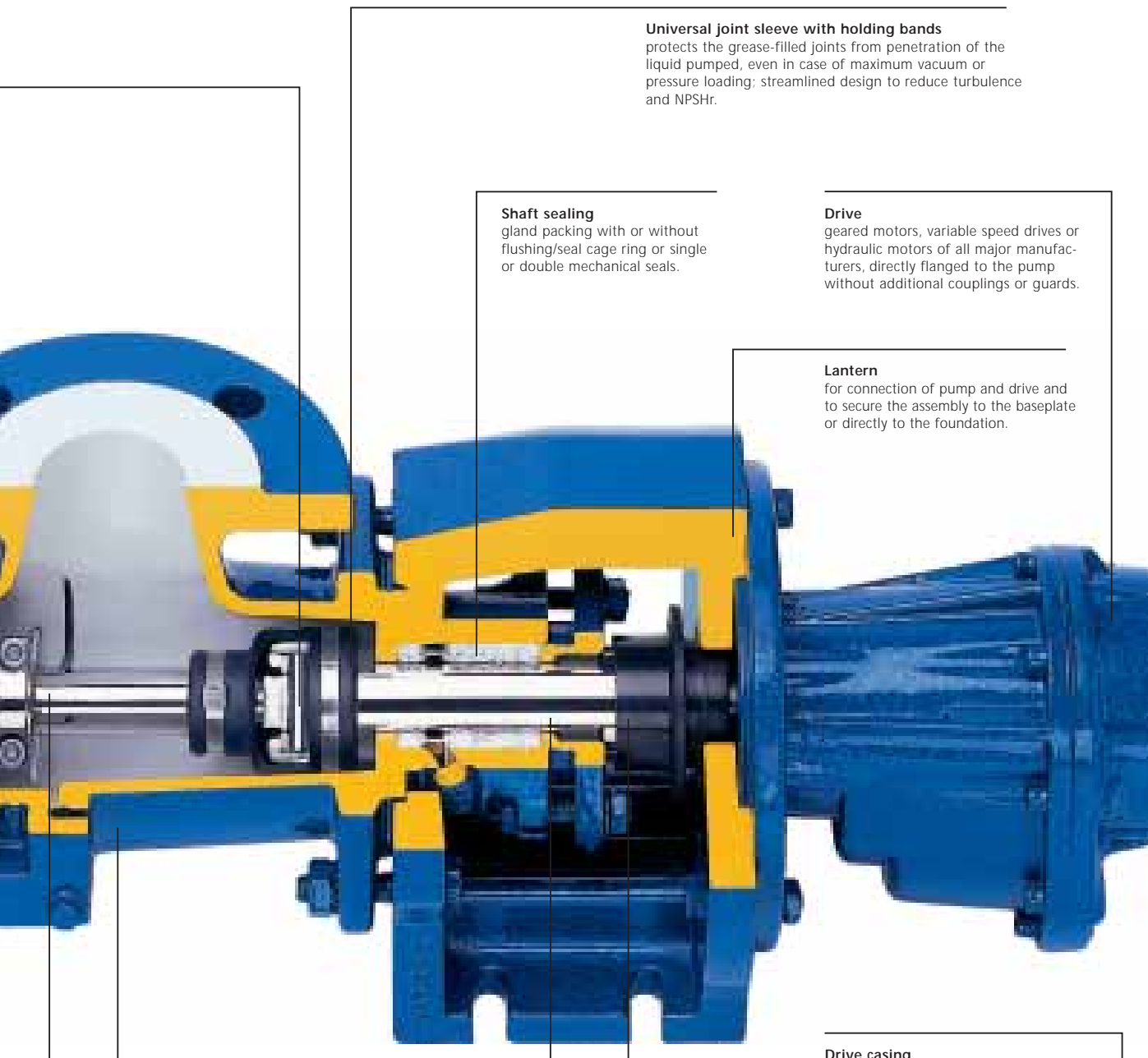

Universal joint sleeve with holding bands
 protects the grease-filled joints from penetration of the liquid pumped, even in case of maximum vacuum or pressure loading; streamlined design to reduce turbulence and NPSHr.

Shaft sealing
 gland packing with or without flushing/seal cage ring or single or double mechanical seals.

Drive
 geared motors, variable speed drives or hydraulic motors of all major manufacturers, directly flanged to the pump without additional couplings or guards.

Lantern
 for connection of pump and drive and to secure the assembly to the baseplate or directly to the foundation.

Suction casing
 with large cross section and designed for smooth flow conditions, with drain plug and connections for pressure/vacuum gauge. Flange connections in DIN or ANSI can be rotated in 90° increments.

Drive casing
 for range NS, drive shaft and bearings can be relubricated, also available with double bearing seals to prevent ingress of dust or moisture.

Plug-in shaft
 connects the drive shaft to the joint; with gland packing the plug-in shaft is used as a shaft protection sleeve; upon request, it is available with wear resistant coating.

Plug-in shaft connection
 for easy dismantling of the pump and drive enabling quick replacement of the rotating parts and shaft seals. The plug-in shaft pin secures the shaft connection to the drive and the splash ring protects the bearing from contamination/gland leakage.

Detail: Range NS



Why standard pumps?

Because they are used in applications such as agriculture, ceramics, chemical and biochemical industry, construction, dyeing and varnishing, electroplating, environment technology, fish industry, food and beverage industry, mining, non-metallic minerals, oil production and offshore technology, petrochemicals, pharmaceutical and cosmetics industry, pulp and paper industry, shipbuilding, sugar industry, supply and waste disposal industry, textile industry, vehicle construction and equipment and wood processing industry.

Features

- Minimal pulsation, controlled flow, so that no pulsation dampers or compensators are required
 - Self-priming, even with air or gas liquid mixtures of up to 9 m (29.5') of water
 - Installation versatility as pumps can be mounted either horizontally or vertically and the suction casing can be rotated
 - Products with solids can be conveyed gently without damage
 - Direction of rotation and fluid flow are reversible
- > Conveying capacity: 30 l/h–500 m³/h (0.13 GPM–2200 GPM),
Pressure: up to 48 bar (720 psi)

Overview of ranges

The drive of BN range pumps is directly flange-mounted to the pump. This means that a separate pump bearing is not necessary and the pump is more compact and less expensive. The plug-in shaft connection between drive and the rotating unit simplifies the replacement of rotating wearing parts and the shaft sealing, thereby making the BN range very service-friendly.

Range BN

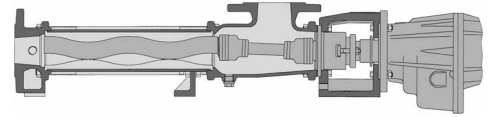

In pumps of the NS range the drives are not directly flange-mounted in favour of a universal configuration of the drives. They have a drive casing and a free shaft end, an elastic coupling or a V-belt and a service-friendly plug-in connection. This simplifies the replacement of the rotating wearing parts and the shaft sealing without dismantling the bearing.

Range NS/N

